

Technology for high productivity

Labeller-Rotating Machine for Inserting Capsules

## **DIVONA 4/8/4**



The rotating ALBAGNAC - DIVONA 4/8/4 labeller is a monoblock of distribution /capping and adhesive labelling adapted to packaging lines with a rate from 3000 to 6000 bottles per /hour.

Designed to meet the requirements connected with high productivity, it enables rapid production changes and makes continuous operation possible thanks to a system of alternate coupling of the labelling machines.

### TOUCH SCREEN

Entry and recording of the settings are carried out through an intuitive and graphical touch screen interface.



This system memorises the setting positions adapted to the format of the products to be labelled and automatically handles their repositioning during a change of product.

The command console is mounted on an articulated arm enabling it to be moved and it supports the operator at all of the intervention points of the machine.

### UP TO 4 LABELLING STATIONS

The electrical and memorized adjustment of the positions of the workstations enable automatic adjustment of the height for positioning the label, to position dropping of the label in accordance with the product's diameter and to adapt its angle over its possible conicity.



So the change in production amounts to simple validation of the pre-recorded programme and changing of the star wheels and back star wheels.

Functioning of the four labelling stations is adjustable to suit.



Every combination is possible:

- 1) The four brushless motorized workstations lay four different labels (front labels, back labels, badges, gold strips...).
- 2) The workstations operate in pairs of the "permutation" type, one ensures automatic lift of the other at the end of the strip without stopping the machine. In this configuration, it is possible to lay up to two labels "non stop" (for example, a front label and a back label), the operator can ensure replacement of the empty bobbins in "concurrent time" without interrupting production.
- 3) It is also possible to reserve two workstations for continuous positioning of labels (in "permutation" mode) and to allocate the two other workstations for positioning additional labels.

The labeller is fitted with high capacity label platforms (Ø max 400) and rewinding of the empty strip is motorized and automatic.

## 8 MOTORIZED TURNTABLES



A carousel, fitted with 8 brushless motorized turntables, enables :

- orientation of each product
- positioning of wrap-around labels
- labelling of bottles of different shapes (square, ovoid...)

## ORIENTATION OF THE PRODUCTS

Adjustment of the orientation of the products before labelling is simplified by the presence of a single sensor for all of the eight turntables.



Orientation of the product can operate either through mechanical detection of the "bottom notch" or via an optical sensor.

## CAPSULES DISTRIBUTOR

The capsules distributor for putting on capsules is fitted with a horizontal high capacity magazine at double level.



The socket system mounted on the rotating jack enables distribution of the capsules at the maximum rate permitted by the machine (6000 products / per hour).

Centring of the neck by a double clip ensures reliable positioning, even on misshapen bottles.

Detection of the presence of a cork via optical cell prohibits distribution of a capsule on a non-corked bottle.

Adjustment of the length and diameter of the capsule is done by knurled knobs.



## FOUR HEAD CAPSULE INSERTION

The rotating capping block is comprised of :



Either 4 capping heads with rollers  
Capping head of the type Albagnac TS8, for aluminium, complex and pewter capsules.

Each capping head is fitting with a chuck in treated steel supporting 8 bi-material rollers mounted on ball bearings.

Or 4 thermal heads



These thermal heads are fitted with a thermal regulation device and ventilation by blowing enabling uniform distribution of the work temperature.

This device ensures completely controlled retraction of the capsules giving a faultless quality finish.

## MACHINE CASING

The entire machine is protected by a safety device divided into sections complying with EC standards.

This protection system enables reloading of a bobbin of labels without stopping the machine while ensuring complete protection for the operator.





## DESCRIPTION

- Capping monoblock for putting on capsules and positioning adhesive labels on all types of cylindrical or shaped (conical, ovoid, square) bottles
- Admissible diameters : 55 to 115 mm
- Touch screen 10"4
- Feeding the bottles by Archimedes screw
- Capping rotary press fitted with 4 Albagnac TS8 heads with electrical height adjustment  
or
- Putting on capsules via 4 thermal regulation heads
- Four labelling machines can operate in pairs of the permutation type for continuous positioning of labels
- Positioning heads on an adjustable support, the height and the angle can be adjusted with memorized electrical command via the touch screen
- Label stop via optical cell with automatic locking of the label exit
- Blocking of the bottles in the labelling phase over 8 brushless motorized turntables
- Low chassis fully encased in stainless steel, with CRAM security protectors divided into sections complying with the standards  $\text{CE}$
- Compact machine : overall width 2200 mm (can supply a bottling lorry)

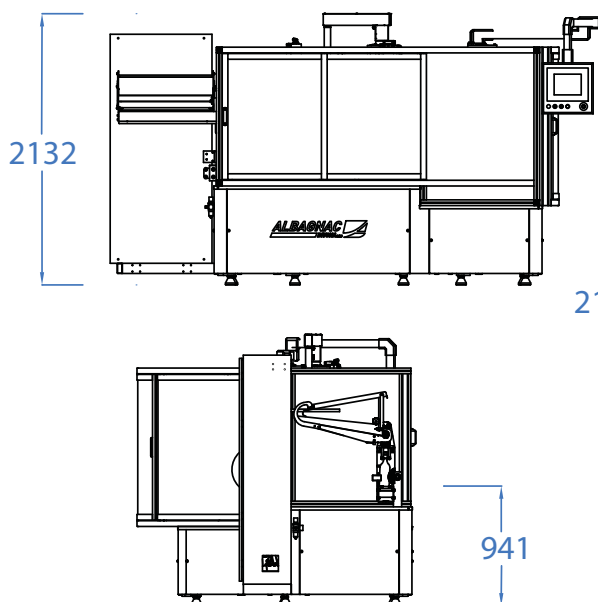

## MAX RATE

- 6000 bottles / per hour

## TECHNICAL CHARACTERISTICS

- Electrical supply :
- 380 Volts three phase + Neutral + Earth
- Electrical power : between 3 and 5 KW
- Pneumatic supply : 5 M<sup>3</sup>/H at 7 bars (20M<sup>3</sup>/H with a capsules distributor)
- Weight: 2000 kg, depending on the devices

## TECHNICAL DATA FOR THE MANUFACTURE OF ADHESIVE LABELS AND CAPSULES

### Labels, back labels, badges:

- Maximum height of the label 170 mm (220 mm on request)
- Ø external roller : 400 mm
- Ø chuck : 76 mm
- Internal winding
- Left front winding

### Capsules:

- Ø max. : 36 mm
- Ø min. : 28 mm
- Max length. : 70 mm

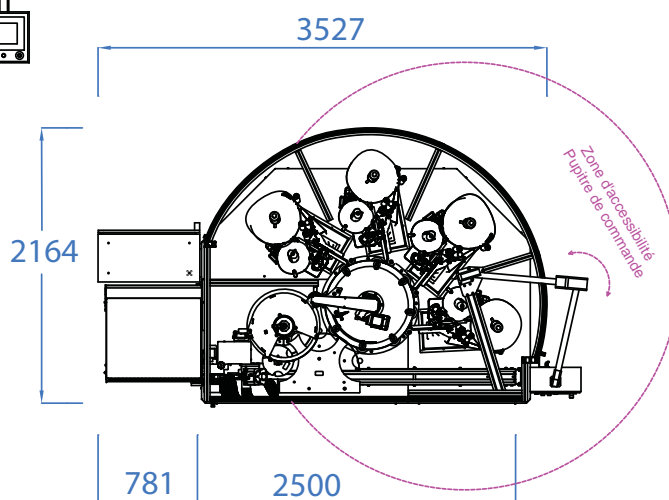

**Albagnac S. A. - Marty - 46140 Sauzet**  
**Tel. + 33 (0)5 65 24 25 20 - Fax + 33 (0)5 65 24 25 10**  
**e-mail: info@albagnac.com**

Simplified Joint Stock Company with capital of 327,000 Euros -  
 Company Registration Number 347 609 042 00010 Principal Activity  
 Code 292HR.C.S. Cahors 88 B 134 - No. FR 23 347 609 042

Your Agent :